

**Shanghai Rowton Display Equipment Co., Ltd.**

Add: Room 1516, Yuzhou Plaza, No. 11, LANE 225 Jimxiang Road, Pudong New  
District, Shanghai, China

Telefon: +86 (0) 21 51353068, 51966305

Fax: +86 (0) 21 5871 5987

Email: [info@rowtondisplay.com](mailto:info@rowtondisplay.com)



PORTABLE DISPLAY SYSTEM

[www.rowtondisplay.com](http://www.rowtondisplay.com)

No.F004

Fabric Frame



## WALL-MOUNTED FABRIC FRAME (WITHOUT LIGHTING)

### Frames



Art. No. WSTF-15

#### Features

- 15 mm. wide aluminum profile
- Single Sided Graphic
- Without Lighting
- 0.28kg/m

#### Applications

- Wallmounted
- Suspended

#### Details

- Ultrathin
- Lightweight
- Customer Size



Art. No. WSTF-32

#### Features

- 32 mm. wide aluminum profile
- Single Sided Graphic
- Without Lighting
- 0.32kg/m

#### Applications

- Wallmounted
- Suspended

#### Details

- Standard Profile
- Customer Size



Art. No. WSTF-35

#### Features

- 35 mm. wide aluminum profile
- Single Sided Graphic
- Without Lighting
- 1.05kg/m

#### Applications

- Wallmounted
- Suspended

#### Details

- Customer Size

### Accessories

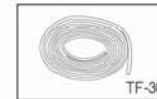
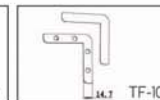
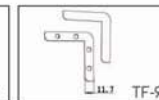





## FREE HANGING FABRIC FRAME (WITHOUT LIGHTING)



### Frames



Art. No. HDTF-45

- Features
- 45mm. wide aluminum profile
  - Double Sided Graphic
  - Without Lighting
  - 0.54kg/m

- Applications
- Freestanding
  - Suspended

- Details
- Standard Profile
  - Customer Size

### Accessories

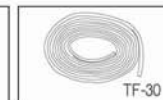



## INFO-WALL FABRIC FRAME (WITHOUT LIGHTING)

### Frames

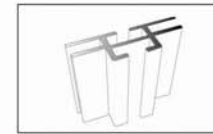

Art. No. HDTF-45

**Features**

- 45mm. wide aluminum profile
- Double Sided Graphic
- Without Lighting
- 0.54kg/m

**Applications**

- Freestanding
- Suspended

**Details**

- Standard Profile
- Customer Size

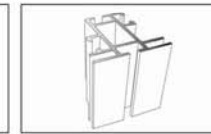

Art. No. SDTF-40

**Features**

- 40mm. wide aluminum profile
- Double Sided Graphic
- Without Lighting
- 0.92kg/m

**Applications**

- Freestanding

**Details**

- Standard Profile
- Customer Size



Art. No. SSTF-28

**Features**

- 28mm. wide aluminum profile
- Single Sided Graphic
- Without Lighting
- 0.75kg/m

**Applications**

- Freestanding

**Details**

- Standard Profile
- Customer Size

### Accessories

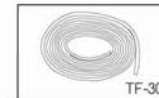
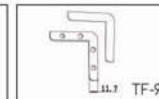
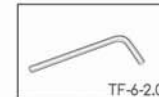



## FREESTANDING SINGLE SIDED FABRIC FRAME

### Frames



Art. No. S5TF-28

#### Features

- 28mm. wide aluminum profile
- Single Sided Graphic
- Without Lighting
- 0.75kg/m

#### Applications

- Freestanding

#### Details

- Standard Profile
- Customer Size



### Accessories

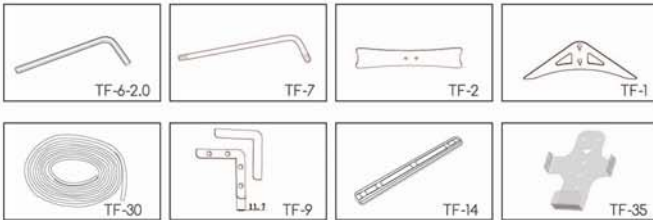



## FREESTANDING DOUBLE SIDED FABRIC FRAME

### Frames



Art. No. HDTF-45

#### Features

- 45mm. wide aluminum profile
- Double Sided Graphic
- Without Lighting
- 0.54kg/m

#### Applications

- Freestanding
- Suspended

#### Details

- Standard Profile
- Customer Size

Art. No. SDTF-40

#### Features

- 40mm. wide aluminum profile
- Double Sided Graphic
- Without Lighting
- 0.92kg/m

#### Applications

- Freestanding

#### Details

- Standard Profile
- Customer Size

### Accessories

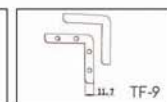
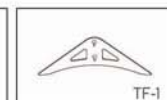
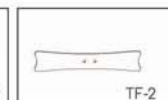
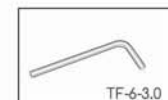

## FREESTANDING TRIPLE SIDED FABRIC FRAME

### Frames



Art. No. TTF-20

- Features
- 20mm. wide aluminum profile
  - Triple sided Graphic
  - Without Lighting
  - 0.5kg/m

- Applications
- Freestanding

- Details
- Customer Size

Art. No. TTF-32

- Features
- 32mm. wide aluminum profile
  - Triple sided Graphic
  - Without Lighting
  - 0.72kg/m

- Applications
- Freestanding

- Details
- Customer Size



### Accessories

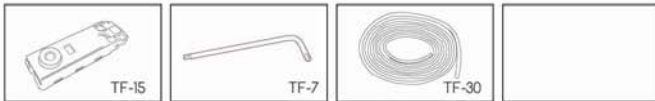

## FREESTANDING CUBE FABRIC FRAME

### Frames

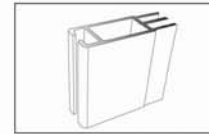

Art. No. CFT-45

- Features
- 45mm. wide aluminum profile
  - Six sided Graphic
  - Without or with Lighting
  - 1.41kg/m

- Applications
- Freestanding

- Details
- Customer Size



### Accessories

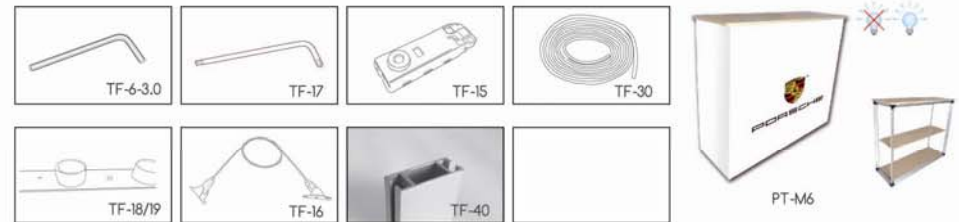



## DOUBLE-SIDED LIGHT BOX

### Frames

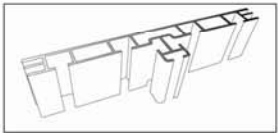

Art. No. LLTF-D180

- Features
- 180mm. wide aluminum profile
  - Double Sided Graphic
  - With Lighting
  - 5.45kg/m

- Applications
- Freestanding

- Details
- LED modules Suitable
  - High bright LED lighting
  - Energy saving up to 70%
  - No heat radiation

### Accessories

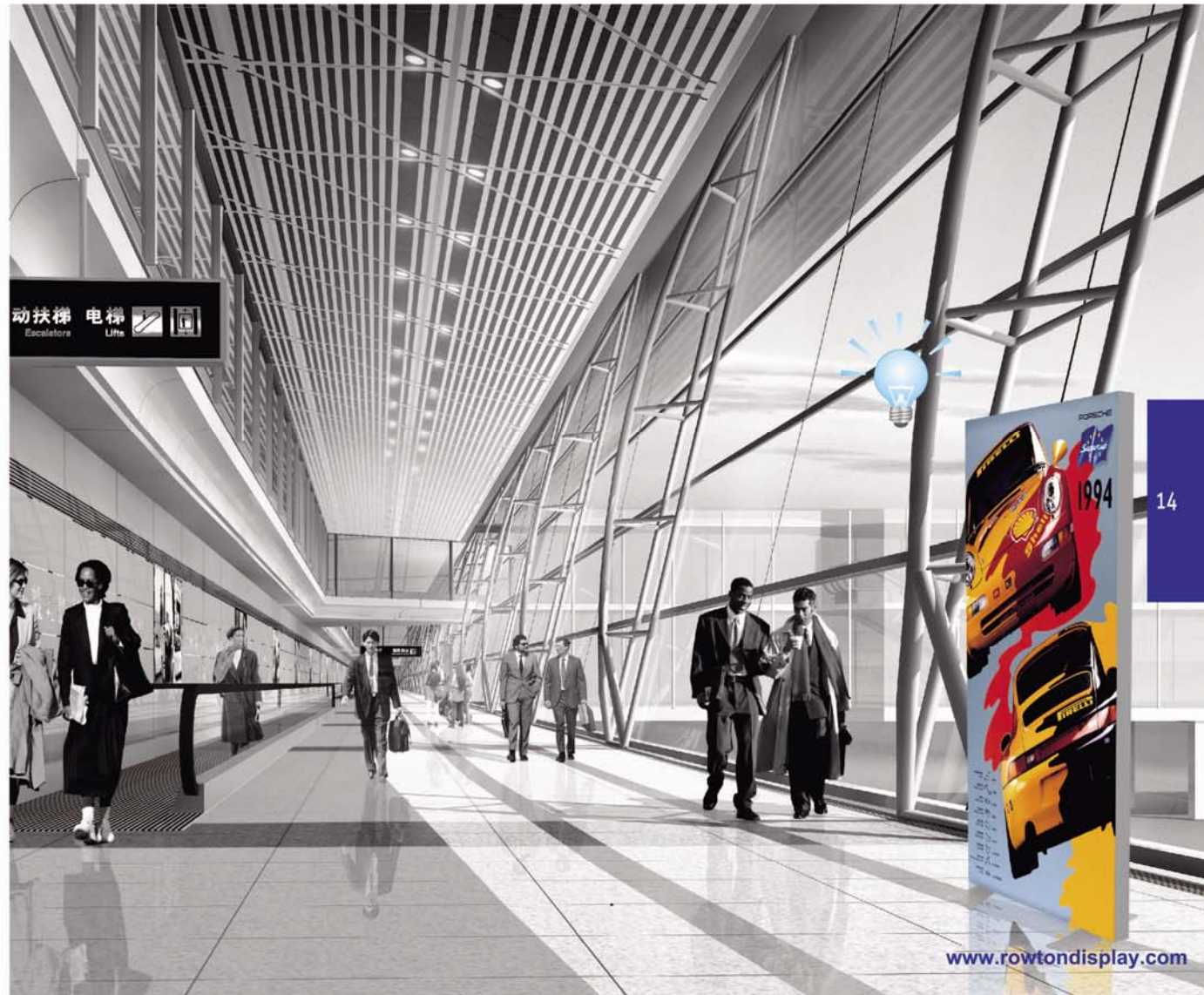
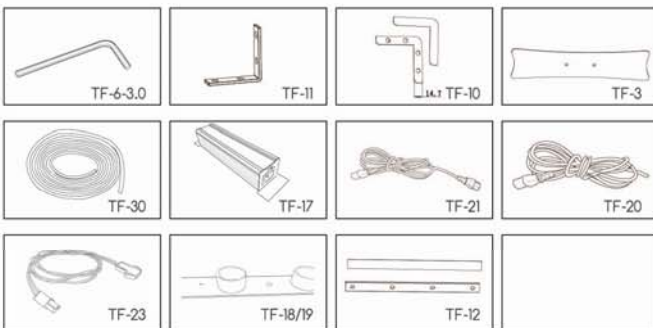

[www.rowtondisplay.com](http://www.rowtondisplay.com)





## SINGLE-SIDED LIGHT BOX

### Frames

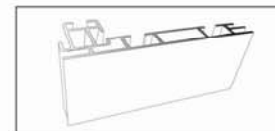

Art. No. LLTF-S100

#### Features

- 100mm. wide aluminum profile
- Single Sided Graphic
- With Lighting
- 2.5kg/m

#### Applications

- Freestanding
- Wallmounted

#### Details

- LED modules Suitable
- High bright LED lighting
- Energy saving up to 70%
- No heat radiation

### Accessories





# THE ILLUMINATION

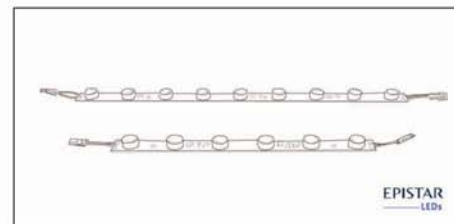

High bright LED Module 9leds/pc 18W Length 530MM  
 High bright LED Module 6leds/pc 12W Length 350MM

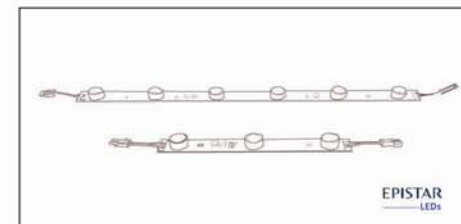

High bright LED Module 6leds/pc 12W Length 500MM  
 High bright LED Module 3leds/pc 6W Length 230MM

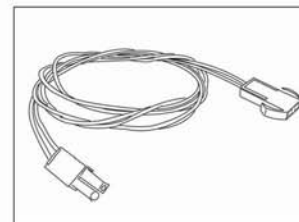

Extension cord 2000mm

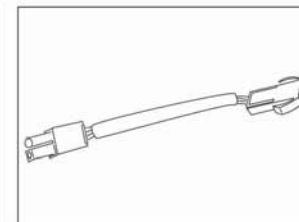

Extension cord 200mm

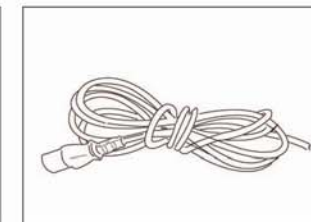

Cable 2500mm (connection cable between adopter and plug)

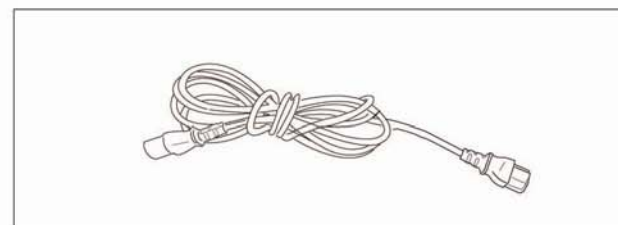

Cable 2000mm (connection cable between adapter and adapter)

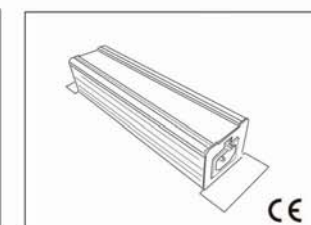

AC adapter 12V 100W (CE)



# OUR ALUMINUM PROFILES



Cubical fabric frame TF-40  Double sided fabric frame CTF-45  Single sided fabric frame WSTF-15  Single sided fabric frame WSTF-32 



Single sided fabric frame SSTF-28  Double sided fabric frame SDTF-40  Double sided fabric frame HDTF-45  Single sided fabric frame WSTF-35 



Triple fabric frame TTF-20  Triple fabric frame TTF-32  Square fabric frame MS-060  Fabric frame MS-051 



Double sided LED fabric frame LLTF-D180  Single sided LED fabric frame LLTF-S100 



# ACCESSORIES

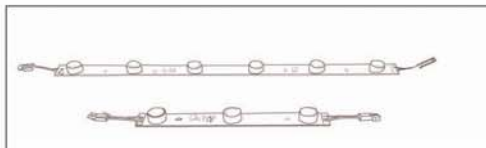

High bright LED Module 18W Length 530MM (TF-191)  
High bright LED Module 12W Length 350MM (TF-192)

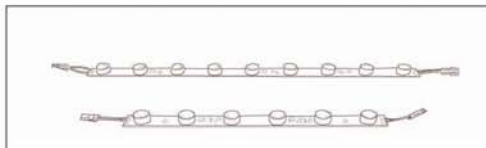

High bright LED Module 12W Length 500MM (TF-181)  
High bright LED Module 6W Length 230MM (TF-182)

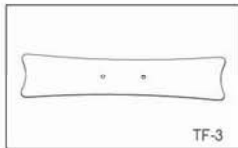

Base Plate (500x110x5mm) TF-3

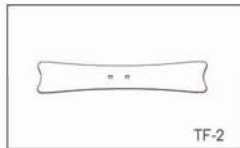

Base Plate (416x80x5mm) TF-2

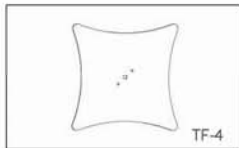

Base Plate (360x360x5mm) TF-4



Base Plate (320x320x5mm) TF-5

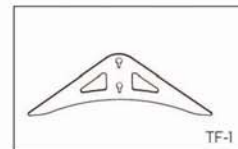

Base Plate (420x147x5mm) TF-1

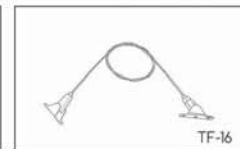

Accessories (1000mm) TF-16

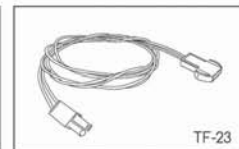

Extension cord (2000mm) TF-23



Extension cord (200mm) TF-22

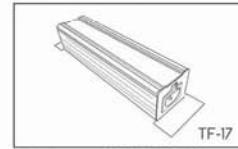

AC adapter 12V 100W (CE) TF-17



Cable (2000mm) TF-21



Cable (2500mm) TF-20

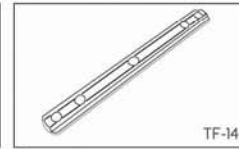

Connector TF-14

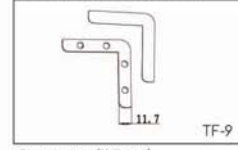

Connector (11.7mm) TF-9

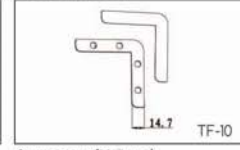

Connector (14.7mm) TF-10



Connector TF-11

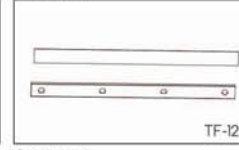

Connector TF-12

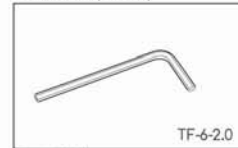

Tools (2.0) TF-6-2.0



Tools (2.5) TF-6-2.5



Tools (3.0) TF-6-3.0



Tools (4.0) TF-6-4.0

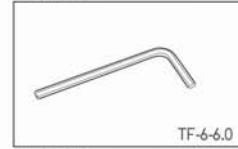

Tools (6.0) TF-6-6.0

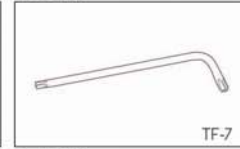

Tools (T30) TF-7



Clear nylon strip (3x10mm) TF-30



Clear nylon strip (4x6mm) TF-31

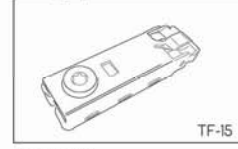

Connector TF-15



Connector TF-8

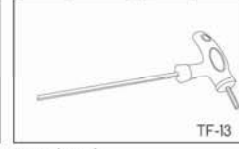

Tools (3mm) TF-13



## TENSION FABRIC STAND

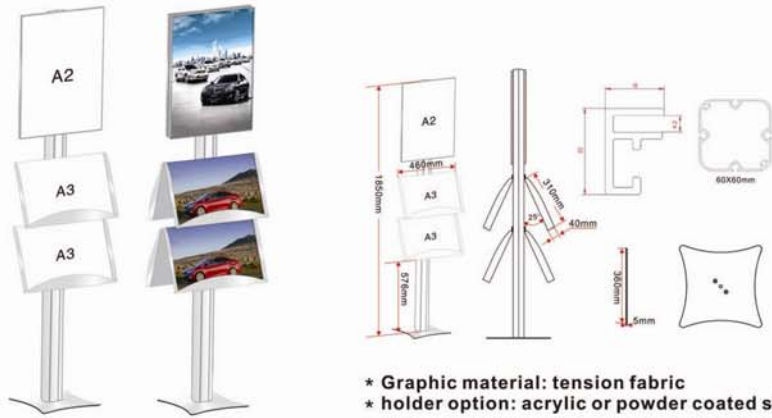

- \* Graphic material: tension fabric
- \* holder option: acrylic or powder coated steel

TS-V001  
Single Side

TS-V002  
Double side

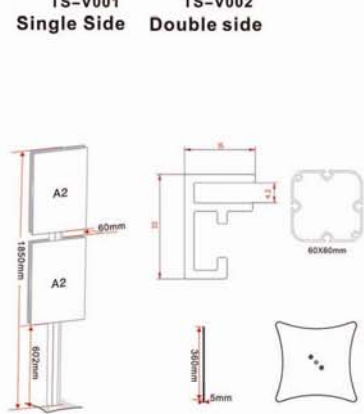

- \* Graphic material: tension fabric



TS-V003  
Single Side

TS-V004  
Double side

## TENSION FABRIC STAND

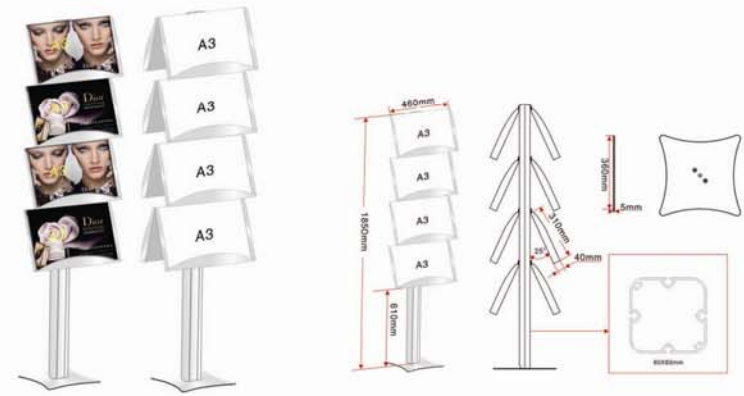

TS-V005  
Single Side

TS-V006  
Double side

- \* holder option: acrylic or powder coated steel



TS-V008  
Single Side

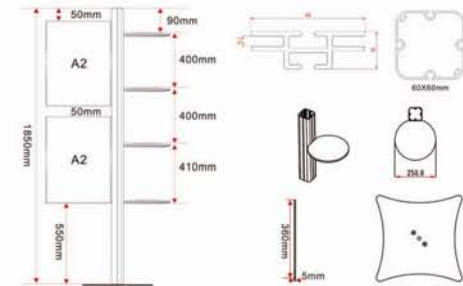

- \* Graphic material: tension fabric
- \* Round shelf: 12mm MDF (color option)

## TENSION FABRIC STAND



TS-V010  
Double side

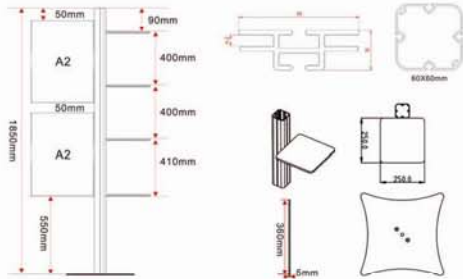

- \* Graphic material: tension fabric
- \* Square shelf: 12mm MDF (color option)

## TENSION FABRIC STAND



TS-V014  
Double Side

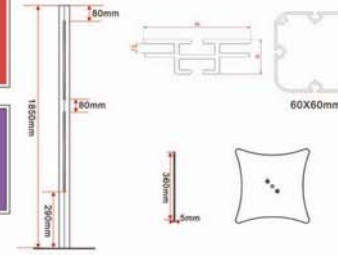

- \* Graphic material: tension fabric



TS-V017  
Double Side



- \* Graphic material: tension fabric
- \* Brouchure holder: 4mm A4 acrylic

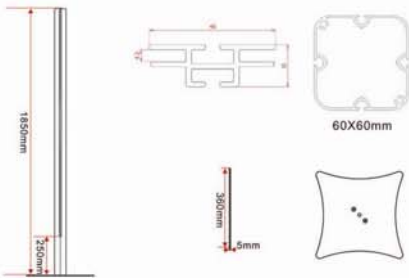

- \* Graphic material: tension fabric



TS-V012  
Double side

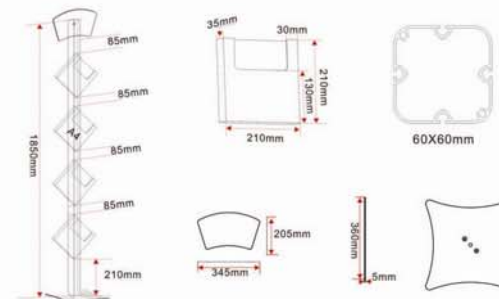

- \* Header: 3mm acrylic
- \* Brouchure holder: A4 acrylic



TS-V015  
Single Side



## SNAP FRAME STAND

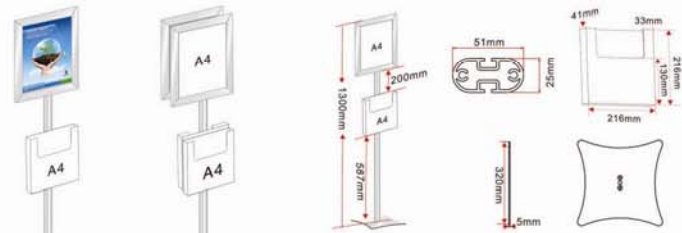

SS-V001  
Single Side

SS-V002  
Double Side

- \* 25mm Snap Frame
- \* 3mm A4 brochure holder

## SNAP FRAME STAND

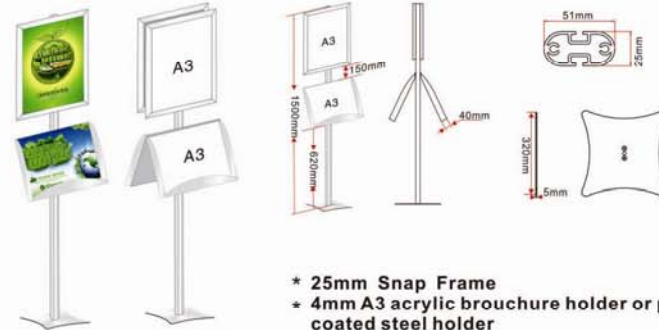

SS-V003  
Single Side

SS-V004  
Double Side

- \* 25mm Snap Frame
- \* 4mm A3 acrylic brochure holder or powder coated steel holder

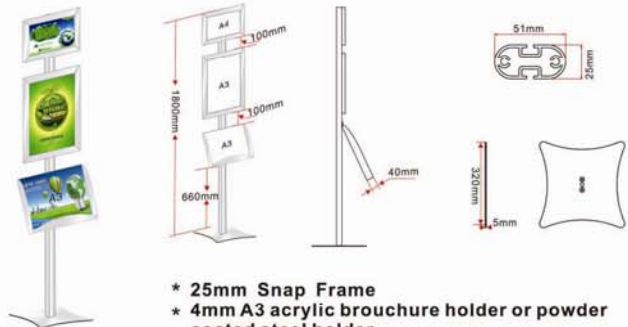

SS-V005  
Single Side

- \* 25mm Snap Frame
- \* 4mm A3 acrylic brochure holder or powder coated steel holder

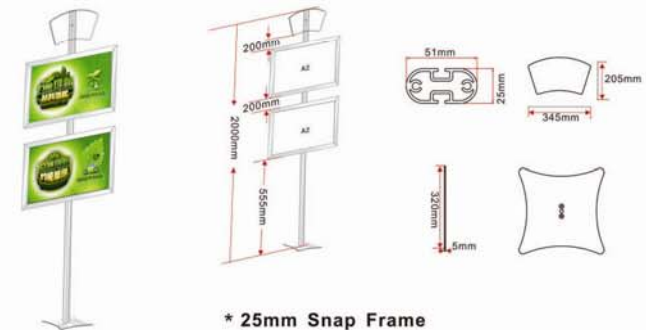

SS-V007  
Single Side

- \* 25mm Snap Frame
- \* Header:3mm acrylic

## SNAP FRAME STAND

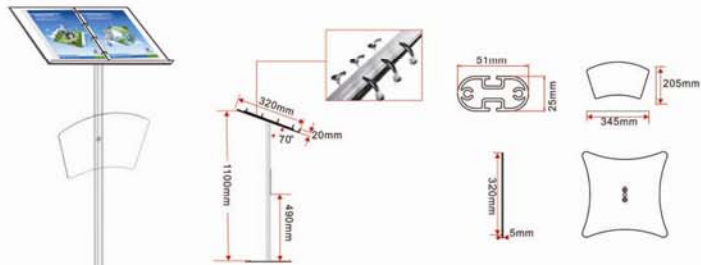

RT-SS-V009  
Single Side

- \* 4mm menuboard
- \* Header: 3mm acrylic

## SNAP-FRAME FLOOR SIGN HOLDER



RT-PS-M1-A3

RT-PS-M1-A4

RT-PS-M2-A4

## MAGNETIC ACRYLIC HOLDER

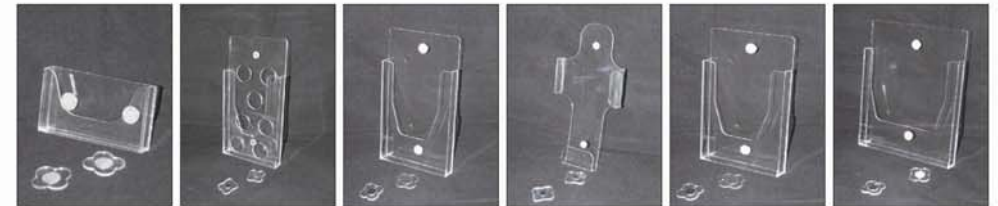

RT-MH-01

RT-MH-02  
1/3A4

RT-MH-03  
1/3A4

RT-MH-04  
1/3A4

RT-MH-05  
A5

RT-MH-06  
A4

## IPAD FLOOR STAND PROP WITH USB CABLE



## TABLET PC BRACKET FOR CAR





## DISPLAY FLOOR STAND BRACKET WITH CABLE



33

## IPAD TABLE FIXING OR WALL-MOUNTING PAD



## ROWTON Digital Printing Service

At present, ROWTON has Fabric printing machine, Dye sublimation printing, photo machine and so on. Except can offer the printing service for Flagpole, Flying banner, Exhibition booth, Roll ups, Snap frames and Pop ups, we are dedicated to the development of textile digital printing, applications and services. With the diversified production of exhibits and display system that give rise to a perfect combination with the digital printing on textile graphic. We employ the most advanced ICC color management system to monitor the color output so as to ensure the color details can satisfy our clients' requirement.



34

### What you need to do

- ★ Pls supply vectorial picture, such as coreldraw, adobe illustrator, photoshop, PDF; or the standard size picture with the resolution 100 to 300.
- ★ To avoid the lack of font, pls make the art with text rasterization.
- ★ The color mode of the picture shoule be CMYK.
- ★ The printed graphic can be washed by common way, but pls don't wash by organic solvent.